



螺旋式螺纹铣刀 Spiral Mill-Thread



螺旋式螺纹铣刀的优点

Advantages of Spiral Mill-Thread Tools

- The spiral designed tools enable a smooth cutting operation at a high feed rate and reduced machining time.
螺旋式设计在高进给率下能够使切削平稳和减少加工时间。
- The tools suit a wide range of applications, from machining small components in small machining centers to heavy-duty applications in high power milling machines.
该工具应用广泛，从加工小零件在小型加工中心到重型高功率铣床
- Spiral fluted toolholders hold 1 to 9 inserts in a comparatively small cutting diameter.
螺旋槽刀杆，在一个相对较小的直径上拥有1-9个刀片安装槽
- The unique clamping method enables optimal indexability. 独特设计的夹持方法使得刀片转位最优化
- Spiral tools reduce vibration and chatter.
螺旋槽设计减少振动和颤颤
- High grade finish is achieved in all applications: threading, end milling roughing and finishing.
高质量的完成所有应用操作：螺纹、端面粗铣加工和精加工。
- Inserts are available in MT7 Sub-Micron Grade with Titanium Aluminum Nitride multi-layer coating (ISO K10 - K20). This is a general purpose grade, which can be used with all materials. 刀片MT7亚微米颗粒级与氮化铝钛复合涂层 (ISO K10—K20) 这是一个通用材质，可用于所有材料

Contents:	Page:	Contents:	Page:		
Product Identification	产品标识	162	Spiral Finishing Inserts	螺旋精铣刀片	168
ISO	各	163	Toolholders	刀杆	169-171
UN	种	164-165	Special Tools	非标刀具	171
Whitworth	螺	165	Case Studies	案例	172
BSPT	纹	166			
NPT	标	166			
NPTF	准	167			
NPS	刀	167			
	片				

三 禄 切 削 刀 具
SUNROXM



上海浦东新区杨新东路248号



Carmex
Precision Tools Ltd.

新产品 - 迷你螺旋槽螺纹铣刀



电话：86-21-58428888

传真：86-21-58423636

上海浦东新区杨新东路248号



螺旋螺纹铣刀片

Product Identification - Ordering Codes 产品标识-订货编号
Spiral Mill - Thread Inserts 螺旋螺纹铣刀片

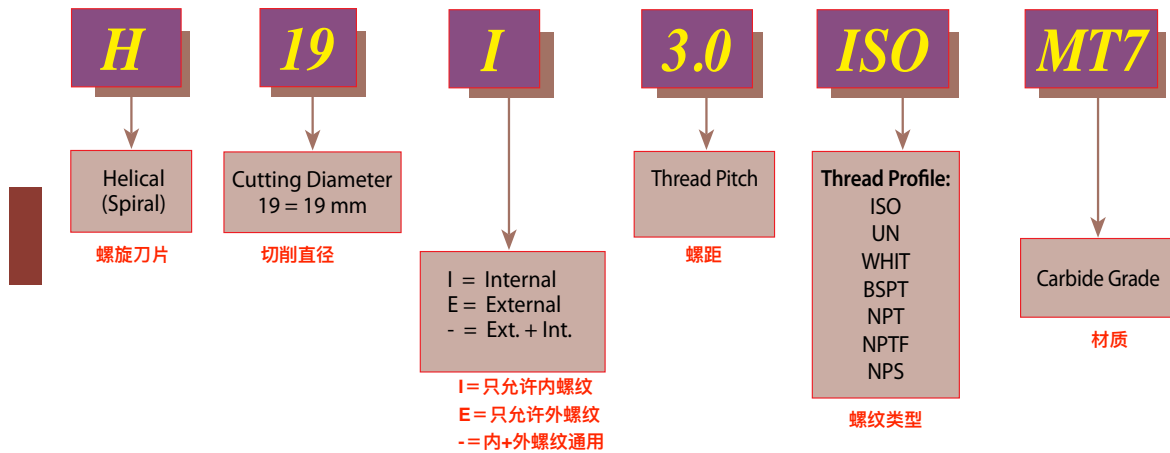

Spiral Mill - Thread Toolholders 螺旋螺纹铣刀杆

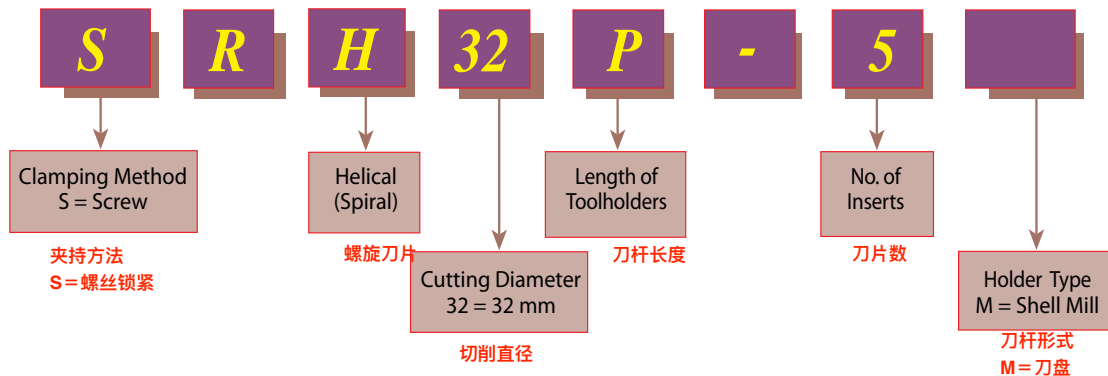



Spiral Mill - Thread Inserts



螺旋螺纹铣刀片

ISO ISO-公制完整牙

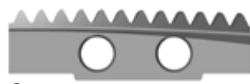
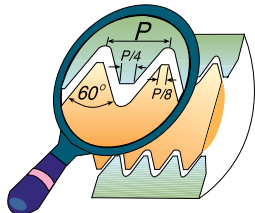

刀片规格 Insert Size	图号 Fig.	螺距 Pitch mm	Ext/Int内 Ext./ Int.	公制粗牙 M coarse	公制细牙 M fine	订货号 Ordering code	适用刀杆 Toolholder
H13	1	1.0	Int.		≥ 15	H13 I 1.0 ISO	SRH13...
		1.5	Int.		≥ 16	H13 I 1.5 ISO	
		2.0	Int.	M16	≥ 17	H13 I 2.0 ISO	
H15	1	1.0	Int.		≥ 17	H15 I 1.0 ISO	SRH15...
		1.5	Int.		≥ 18	H15 I 1.5 ISO	
		2.0	Int.		≥ 19	H15 I 2.0 ISO	
		2.5	Int.	M18	≥ 20	H15 I 2.5 ISO	
H17	1	1.0	Int.		≥ 19	H17 I 1.0 ISO	SRH17...
		1.5	Int.		≥ 20	H17 I 1.5 ISO	
		2.0	Int.		≥ 21	H17 I 2.0 ISO	
H19	1	2.5	Int.	M20, M22	≥ 22	H17 I 2.5 ISO	SRH19...
		2.0	Int.		≥ 23	H19 I 2.0 ISO	
H19	1	3.0	Int.	M24	≥ 25	H19 I 3.0 ISO	SRH19...
		1.0	Ext.			H23 E 1.0 ISO	
H23	2	1.0	Int.		≥ 25	H23 I 1.0 ISO	SRH23...
		1.5	Ext.			H23 E 1.5 ISO	
		1.5	Int.		≥ 26	H23 I 1.5 ISO	
		2.0	Ext.			H23 E 2.0 ISO	
		2.0	Int.		≥ 27	H23 I 2.0 ISO	
		3.0	Ext.			H23 E 3.0 ISO	
		3.0	Int.	M27	≥ 29	H23 I 3.0 ISO	
		3.5	Int.	M30, M33	≥ 30	H23 I 3.5 ISO	
		4.0	Int.	M36	≥ 31	H23 I 4.0 ISO	
H32	2	1.0	Int.		≥ 34	H32 I 1.0 ISO	SRH32...
		1.5	Ext.			H32 E 1.5 ISO	
		1.5	Int.		≥ 35	H32 I 1.5 ISO	
		2.0	Ext.			H32 E 2.0 ISO	
		2.0	Int.		≥ 36	H32 I 2.0 ISO	
		3.0	Ext.			H32 E 3.0 ISO	
		3.0	Int.		≥ 38	H32 I 3.0 ISO	
		3.5	Int.		≥ 39	H32 I 3.5 ISO	
		4.0	Ext.			H32 E 4.0 ISO	
		4.0	Int.	M39	≥ 40	H32 I 4.0 ISO	
H45	2	4.5	Int.	M42, M45	≥ 41	H32 I 4.5 ISO	SRH45...
		5.0	Int.	M48	≥ 42	H32 I 5.0 ISO	
		1.5	Ext.			H45 E 1.5 ISO	
		1.5	Int.		≥ 48	H45 I 1.5 ISO	
		2.0	Ext.			H45 E 2.0 ISO	
H45	2	2.0	Int.		≥ 49	H45 I 2.0 ISO	SRH45...
		3.0	Int.		≥ 51	H45 I 3.0 ISO	
		3.5	Int.		≥ 52	H45 I 3.5 ISO	
		4.0	Int.		≥ 53	H45 I 4.0 ISO	
		4.5	Int.		≥ 54	H45 I 4.5 ISO	
		5.0	Int.	M52	≥ 55	H45 I 5.0 ISO	
		5.5	Int.	M56, M60	≥ 56	H45 I 5.5 ISO	
		6.0	Int.	M64, M68	≥ 57	H45 I 6.0 ISO	
		H63	2	1.5	Int.		
2.0	Int.				≥ 67	H63 I 2.0 ISO	
3.0	Int.				≥ 69	H63 I 3.0 ISO	
4.0	Int.				≥ 71	H63 I 4.0 ISO	
6.0	Int.				≥ 75	H63 I 6.0 ISO	



Spiral Mill - Thread Inserts

螺旋螺纹铣刀片

UN UN-完整牙

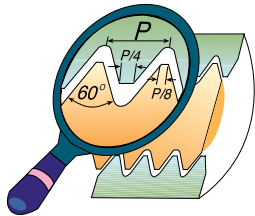

刀片规格	图号	牙数	内/外	美制-UN/UNC/UNF/UNS				订货号	适用刀杆	
Insert Size	Fig.	Pitch TPI	Ext./ Int.	UN	UNC	UNF	UNS	Ordering code	Toolholder	
H13	1	16	Int.	5/8, 11/16				H13 I 16 UN	SRH13...	
		14	Int.				5/8	H13 I 14 UN		
		12	Int.	11/16				H13 I 12 UN		
H15	1	16	Int.			3/4		H15 I 16 UN	SRH15...	
		14	Int.				3/4	H15 I 14 UN		
		12	Int.	3/4, 13/16				H15 I 12 UN		
		10	Int.		3/4		7/8, 1	H15 I 10 UN		
H17	1	16	Int.	13/16 - 1				H17 I 16 UN	SRH17...	
		14	Int.			7/8, 1		H17 I 14 UN		
		12	Int.	7/8				H17 I 12 UN		
H19	1	9	Int.		7/8			H17 I 9 UN	SRH19...	
		12	Int.	15/16		1		H19 I 12 UN		
H19	1	8	Int.	1 1/16, 1 1/8	1			H19 I 8 UN	SRH19...	
		32	Int.	1			1 - 1 1/4	H23 I 32 UN		
H23	2	24	Int.					H23 I 24 UN	SRH23...	
		20	Ext.					H23 E 20 UN		
		20	Int.	1 1/16 - 1 5/16						H23 I 20 UN
		18	Ext.					H23 E 18 UN		
		18	Int.				1	H23 I 18 UN		
		16	Ext.					H23 E 16 UN		
		16	Int.	1 1/16 - 1 5/16						H23 I 16 UN
		14	Ext.					H23 E 14 UN		
		14	Int.					≥1 1/8		H23 I 14 UN
		12	Ext.							H23 E 12 UN
		12	Int.	1 1/16 - 1 3/16			1 1/8			H23 I 12 UN
		10	Ext.							H23 E 10 UN
		10	Int.					≥1 1/8		H23 I 10 UN
		8	Ext.							H23 E 8 UN
		8	Int.	1 3/16 - 1 5/16						H23 I 8 UN
7	Ext.						H23 E 7 UN			
7	Int.				1 1/4		H23 I 7 UN			
H28	2	12	Int.	1 5/16		1 1/4, 1 3/8		H28 I 12 UN	SRH28...	
		8	Int.	1 3/8 - 1 7/16				H28 I 8 UN		
		6	Int.	1 3/8 - 1 9/16	1 1/2			H28 I 6 UN		
H32	2	24	Ext.				≥1 3/8	H32 E 24 UN	SRH32...	
		20	Ext.					H32 E 20 UN		
		20	Int.	≥1 3/8				H32 I 20 UN		
		18	Ext.					H32 E 18 UN		
		18	Int.				≥1 3/4	H32 I 18 UN		
		16	Ext.					H32 E 16 UN		
		16	Int.	1 3/8 - 1 7/8				H32 I 16 UN		
		12	Ext.					H32 E 12 UN		
		12	Int.	1 7/16 - 1 7/8		1 1/2		H32 I 12 UN		
		8	Ext.					H32 E 8 UN		
		8	Int.	1 1/2 - 2				H32 I 8 UN		
6	Ext.					H32 E 6 UN				
6	Int.	1 5/8 - 1 7/8				H32 I 6 UN				
5	Int.			1 3/4			H32 I 5 UN			
H40	2	6	Int.	1 15/16, 2				H40 I 6 UN	SRH40...	
		4.5	Int.		2			H40 I 4.5 UN		



Spiral Mill - Thread Inserts

螺旋螺纹铣刀片

UN UN-完整牙

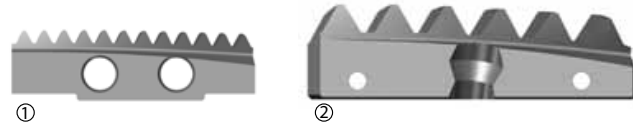
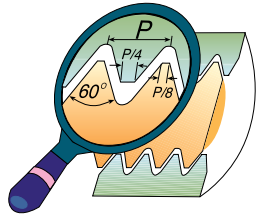

刀片规格	图号	牙数	内外	美制-UN/UNC/UNF/UNS				订货号	适用刀杆
Insert Size	Fig.	Pitch TPI	Ext./ Int.	UN	UNC	UNF	UNS	Ordering code	Toolholder
H45	2	16	Int.	1 15/16 - 2 1/2			2 1/16 - 2	H45 I 16 UN	SRH45...
		12	Int.	1 15/16 - 2 5/8				H45 I 12 UN	
		8	Int.	2 1/8 - 2 5/8				H45 I 8 UN	
		6	Int.	2 1/8 - 2 3/4				H45 I 6 UN	
		4.5	Int.		2 1/4			H45 I 4.5 UN	
		4	Int.		2 1/2 - 2 3/4			H45 I 4 UN	
H63	2	16	Int.	≥2 5/8				H63 I 16 UN	SRH63...
		12	Int.	≥2 3/4				H63 I 12 UN	
		8	Int.	≥2 3/4				H63 I 8 UN	
		6	Int.	≥2 7/8				H63 I 6 UN	
		4	Int.		≥3			H63 I 4 UN	

Whitworth 英国惠氏螺纹

Same insert for internal and external thread 内、外螺纹通用

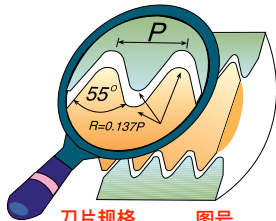

刀片规格	图号	每吋牙数	① 订货号	② 螺纹规格	适用刀杆
Insert Size	Fig.	Pitch TPI	Ordering code	Thread Size	Toolholder
H13	1	19	H13- 19 W	G 3/8	SRH13...
H15	1	14	H15- 14 W	G 1/2	SRH15...
H17	1	14	H17- 14 W	G 1/2 - 5/8	SRH17...
		11	H17- 11 W	G ≥ 1"	
H19	1	14	H19- 14 W	G 3/4 - 7/8	SRH19...
		11	H19- 11 W	G ≥ 1"	
H23	2	14	H23-14 W	Int. G 7/8"	SRH23...
		11	H23-11 W	Ext. ≥ G 1/2"	
H32	2	14	H32-14 W	≥ G 1"	SRH32...
		11	H32-11 W	Ext. ≥ G 1/2"	
H45	2	11	H45-11 W	Int. ≥ G 1 1/8"	SRH45...
		11	H45-11 W	Ext. ≥ G 1"	
H63	2	11	H63-11 W	Int. ≥ G 2 3/8"	SRH63...
				Ext. ≥ G 1"	



BSPT 英制锥管螺纹-BSPT

Same insert for internal and external thread 内、外螺纹通用

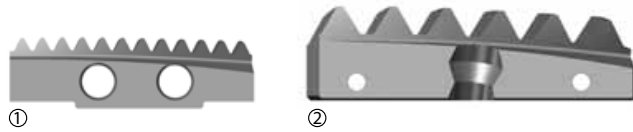
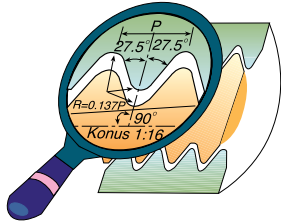

刀片规格 Insert Size	图号 Fig.	图号 Pitch TPI	订货号 Ordering code	螺纹规格 Thread Size	适用刀杆 Toolholder
H13	1	19	H13-19 BSPT	3/8	SRH13...
H15	1	14	H15-14 BSPT	1/2 - 3/4	SRH15...
H17	1	14	H17-14 BSPT	1/2 - 3/4	SRH17...
H23	2	11	H23-11 BSPT	≥ 1"	SRH23...
H32	2	11	H32-11 BSPT	Int. ≥ 1 1/8" Ext. ≥ 1"	SRH32...
H45	2	11	H45-11 BSPT	Int. ≥ 1 3/4" Ext. ≥ 1"	SRH45...
H63	2	11	H63-11 BSPT	Int. ≥ 2 1/2" Ext. ≥ 1"	SRH63...

NPT 美制NPT锥管螺纹

Same insert for internal and external thread 内、外螺纹通用

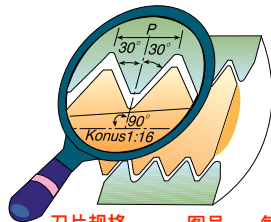

刀片规格 Insert Size	图号 Fig.	每吋牙数 Pitch TPI	订货号 Ordering code	螺纹规格 Thread Size	适用刀杆 Toolholder
H13	1	18	H13-18 NPT	3/8	SRH13...
H15	1	14	H15-14 NPT	1/2 - 3/4	SRH15...
H17	1	14	H17-14 NPT	1/2 - 3/4	SRH17...
H23	2	11.5	H23-11.5 NPT	1"-2"	SRH23...
H32	2	11.5	H32-11.5 NPT	Int. 1 1/4"-2" Ext. 1"-2"	SRH32...
H45	2	11.5	H45-11.5 NPT	Int. ≥ 1 5/8" Ext. ≥ 1"	SRH45...
		8	H45-8 NPT	≥ 2 1/2"	
H63	2	11.5	H63-11.5 NPT	Ext. 1-2"	SRH63...
		8	H63-8 NPT	≥ 3"	



Spiral Mill - Thread Inserts

螺旋螺纹铣刀

NPTF 美制-NPTF-密封锥管螺纹

Same insert for internal and external thread 内、外螺纹通用

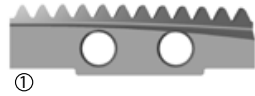
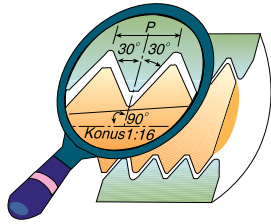

刀片规格	图号	每吋牙数	订货号	螺纹规格	适用刀杆
Insert Size	Fig.	Pitch TPI	Ordering code	Thread Size	Toolholder
H13	1	18	H13-18 NPTF	3/8	SRH13...
H15	1	14	H15-14 NPTF	1/2 - 3/4	SRH15...
H17	1	14	H17-14 NPTF	1/2 - 3/4	SRH17...
H23	2	11.5	H23-11.5 NPTF	1"-2"	SRH23...
H32	2	11.5	H32-11.5 NPTF	Int. 1 1/4"-2" Ext. 1" -2"	SRH32...

NPS 美制-NPS

Same insert for internal and external thread 内、外螺纹通用



刀片规格	每吋牙数	订货号	螺纹规格	适用刀杆
Insert Size	Pitch TPI	Ordering code	Thread Size	Toolholder
H13	18	H13- 18 NPS	3/8	SRH13...
H15	14	H15- 14 NPS	1/2 - 3/4	SRH15...
H17	14	H17- 14 NPS	1/2 - 3/4	SRH17...



螺旋精铣刀片

Spiral Finishing Inserts

螺旋精铣刀片

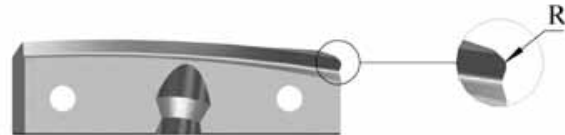

刀片规格 Insert Size	刀尖 R	订货号 Ordering code	适用刀杆 Toolholder
H23	0.2	H23 F R 0.2	SRH23...
	0.5	H23 F R 0.5	
	1.0	H23 F R 1.0	
H32	0.2	H32 F R 0.2	SRH32...
	0.5	H32 F R 0.5	
	1.0	H32 F R 1.0	
H45	0.2	H45 F R 0.2	SRH45...
	0.5	H45 F R 0.5	
	1.0	H45 F R 1.0	
	1.5	H45 F R 1.5	
	2.0	H45 F R 2.0	
H63	0.2	H63 F R 0.2	SRH63...
	0.5	H63 F R 0.5	
	1.0	H63 F R 1.0	
	1.5	H63 F R 1.5	
	2.0	H63 F R 2.0	



Spiral Mill - Thread Toolholders



螺旋螺纹铣刀杆

Toolholders

刀杆

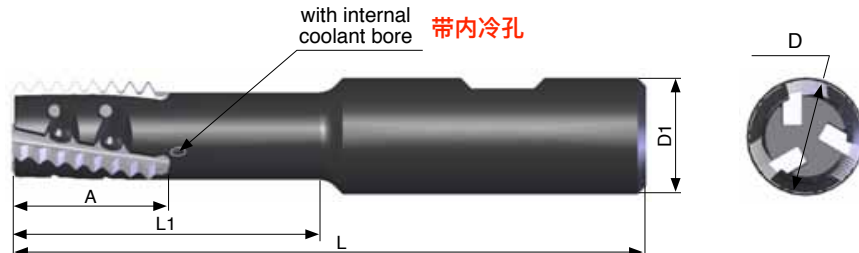

订货号	刀片型号	刀片规格					刀片数	螺丝	扳手
Ordering Code	Insert Type	Insert size A	D	D1	L	L1	No. of Inserts	Screw	Key
SRH13-1	H13	27	13	20	90	35	1	S13	K11
SRH15-1	H15	27	15	20	95	40	1	S15	K11
* SRH17-2	H17	27	17	20	85	30	2	S17	K11
* SRH17J-2	H17	27	17	20	100	45	2	S17	K11
SRH19-3	H19	27	19	20	85	30	3	S19	K11
SRH19J-3	H19	27	19	20	110	55	3	S19	K11

* When using NPT, NPTF, BSPT inserts the cutting diameter D = 18 mm

* 当使用NPT,NPTF,BSPT刀片切削直径=18mm时

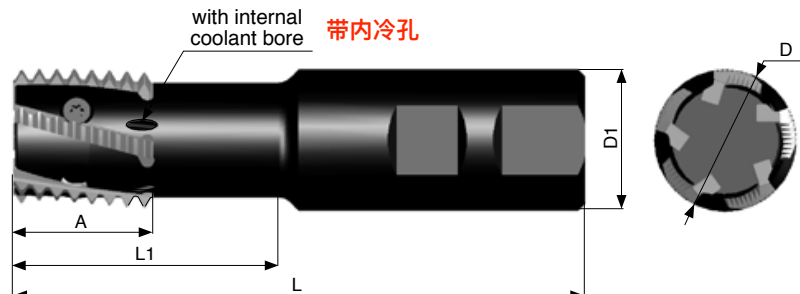

订货号	刀片型号	刀片规格					刀片数	螺丝	扳手
Ordering Code	Insert Type	Insert size A	D	D1	L	L1	No. of Inserts	Screw	Key
SRH23-2	H23	27	23	25	110	50	2	S23	K21
SRH23M-2	H23	27	23	25	150	75	2	S23	K21
SRH28-3	H28	32	28	32	150	75	3	S32S	K22
SRH32-5	H32	32	32	32	130	60	5	S32	K22
SRH32P-5	H32	32	32	32	180	90	5	S32	K22



Spiral Mill - Thread Toolholders

螺旋螺纹铣刀杆

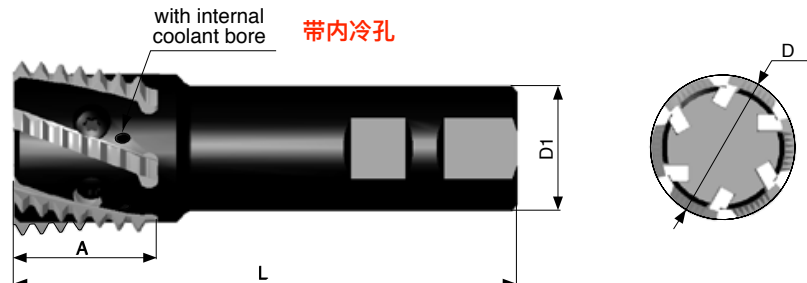

订货号	刀片型号	刀片规格				刀片数	螺丝	扳手
Ordering Code	Insert Type	Insert size A	D	D1	L	No. of Inserts	Screw	Key
SRH40-4	H40	37	40	32	180	4	S45S	K40
SRH45-6	H45	37	45	32	130	6	S45	K40

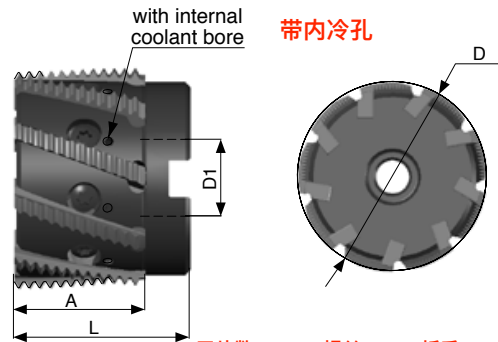

订货号	刀片型号	刀片规格				刀片数	螺丝	扳手
Ordering Code	Insert Type	Insert size A	D	D1	L	No. of Inserts	Screw	Key
SRH32-5M	H32	32	32	16	52	5	S32S	K22
SRH45-6M	H45	37	45	22	60	6	S45S	K40
SRH63-9	H63	38	63	22	50	9	S63	K40



Case Studies 案例

Case Study no. 1 案例 1

Thread 螺纹	M56x1.5 M56×1.5
Internal/External 内、外	Internal 内
Thread Length 螺纹深度	33.0 33mm
Raw Material 材料处理	Ductile Iron 可锻铸铁
Cutting Speed - Vc 切削速度	130 m/min 130m/min
Tooth Load - Fz 每齿进给	0.15 mm/tooth 0.15mm/tooth
Toolholder 刀杆	SRH45 - 6 SRH45-6
Insert 刀片	H45 I 1.5 ISO MT7 H45 I 1.5 ISO MT7
Result 效果	600 pcs with 0.02 offset 600件带0.02偏差 (Competitor - 40 pcs with 0.15 offset) 竞争对手40件带0.15偏差



Case Study no. 2 案例 2

Application 应用	Grooves Milling 螺旋槽铣
Internal/External 内、外	External 外
Raw Material 材料处理	Cast Steel 铸钢
Cutting Speed - Vc 切削速度	195 m/min 195m/min
Tooth Load - Fz 每齿进给	0.10 mm/tooth 0.10mm/tooth
Toolholder 刀杆	SRH63 - 9 SRH63-9
Insert 刀片	Taylor Made H63 H63
Result 结果	1350 pcs 1350件 (Competitor - 540 pcs) 竞争对手540件

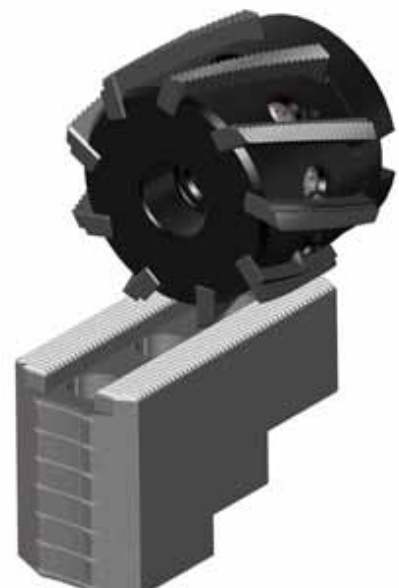

三 禄 切 削 刀 具
SUNROXM



上海三禄贸易有限公司



Carmex
Precision Tools Ltd.